

KPM-300LA-16AS21

This module designed for light emitting display device.
 Organize with 16×16 matrix combination with 256 of
 each Red,PGreen LED Chips, for Outdoor use

FEATURES

- Active display size(x*y) : 300mm × 300mm
- Dot pitch : 18.75mm
- Display color : RED,PGREEN, AMBER(3 color)
- Duty rate : Static
- Dot matrix(x*y) : 256(16×16)
- Viewing angle : 75°/35°
- Weight : 1900g(Typ.)

ABSOLUTE MAXIMUM RATINGS

ITEM	SYMBOL	RATINGS	UNIT
Power dissipation	P	50	W
Supply voltage(DRIVE)	V _{DD}	5	V
Supply voltage(LED)	V _{LED}	5	V
Logic input power	V _{in}	-0.5 ~ V _{DD}	V
Junction Temp.	T _j	115	°C
Operating Temp.	T _{opr}	-20 ~ +65	°C
Storage Temp.	T _{stg}	-20 ~ +70	°C

OPTICAL CHARACTE RISTICS

Ta=25°C

ITEM		SYMBOL	CONDITION	MIN.	TYP.	MAX.	UNIT
Brightness (16 * 16)	GREEN	I _{v_g}	V _{DD} = 5V V _{LED} = 5V	-	5,400	-	cd/m ²
	RED	I _{v_r}		-	3,100	-	
	-	-		-	-	-	
	AMBER	I _{v_o}		-	8,500	-	
Supply-current(LED)	GREEN	I _{LEDg}		-	5.0	-	A
	RED	I _{LEDr}		-	5.0	-	
	AMBER	I _{LEDa}		-	10.0	-	
Emisson Wavelength	GREEN	λP _g		-	525	-	nm
	RED	λP _r		-	625	-	
	BLUE	λP _b		-	470	-	

DIMENSION

(Unit : mm)

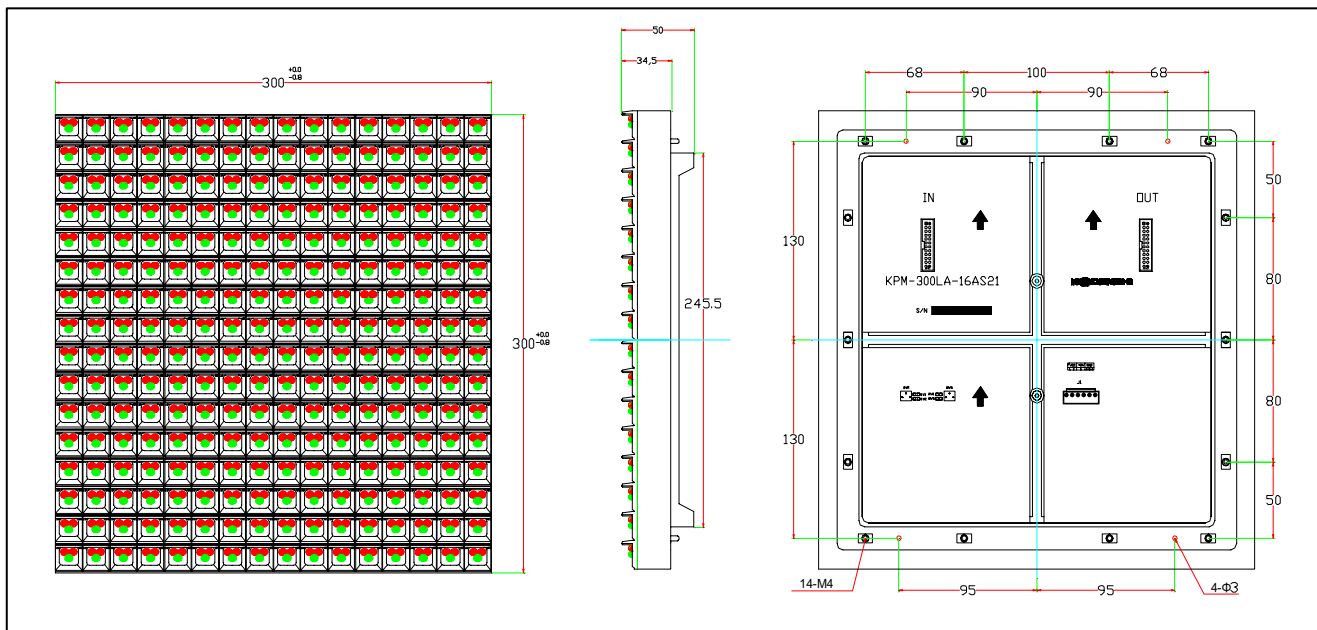

KPM-300LA-16AS21

INTERFACE

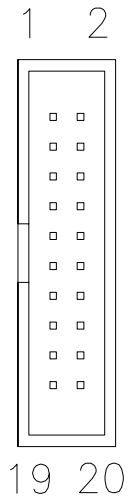

connector pin number & signal function

PIN NO	SIGNAL	SIGNAL-FUNCTIO
1	GND	GROUND
2	GND	GROUND
3	R0_DATA	Data input for red color
4	G0_DATA	Data input for green color
5	R1_DATA	Data input for red color
6	G1_DATA	Data input for green color
7	R2_DATA	Data input for red color
8	G2_DATA	Data input for green color
9	R3_DATA	Data input for red color
10	G3_DATA	Data input for green color
11	GND	GROUND
12	GND	GROUND
13	ROE	RED DISPLAY ON/OFF SIGNAL
14	GND	GROUND
15	GOE	GREEN DISPLAY ON/OFF SIGNAL
16	GND	GROUND
17	LAT	DATA LATCH SIGNAL
18	GND	GROUND
19	CLK	DATA SHIFT SIGNAL
20	GND	GROUND

Power connector pin number & signal function

PIN NO	SIGNAL	LEVEL	SIGNAL-FUNCTIO	WIRE COLOR
1	VLED	5 [V]	POWER OF THE LED	WHITE
2			Power of the LOGIC	
3	5V			
4	GND	0 [V]	GROUND	BLACK
5				
6				

TIMING CHART MODULE(16 x 16) DISPLAY

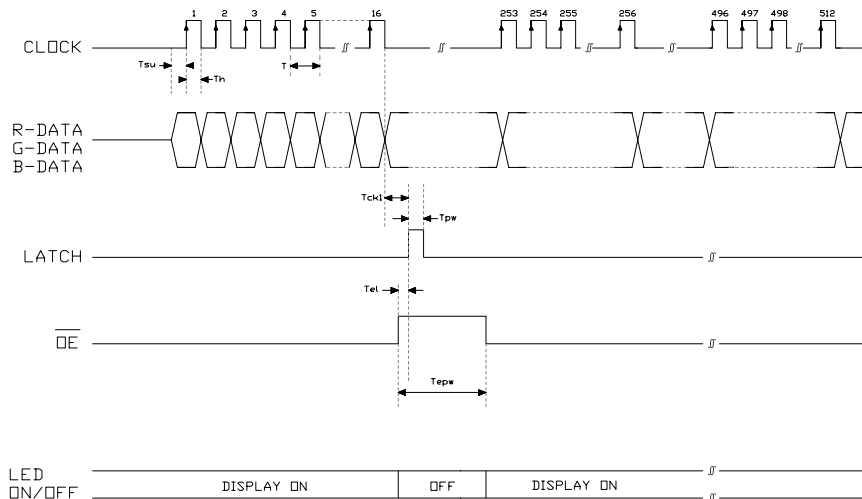

NO	ITEM	SYMBOL	MIN.	TYP.	MAX.	UNIT
1	CLOCK CYCLE	T	-	-	25	MHz
2	LATCH HOLD TIME	T _{ckl}	15	-	-	ns
3	LATCH PULSE WIDTH	T _{pw}	50	-	-	ns
4	ENABLE- LATCH TIME	T _{el}	50	-	-	μs
5	ENABLE PULSE WIDTH	T _{epw}	100	-	-	μs
6	DATA SETUP TIME	T _{su}	10	-	-	ns
7	DATA HOLD TIME	T _h	15	-	-	ns

KPM-300LA-16AS21

CONNECTOR SPECIFICATION

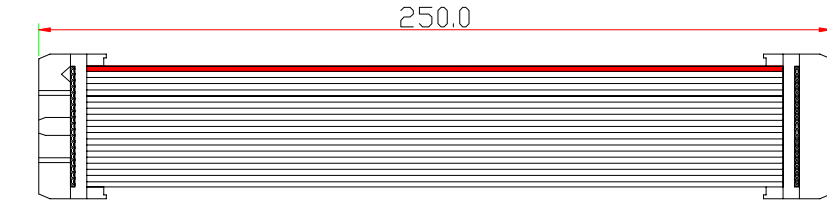

DATA CABLE

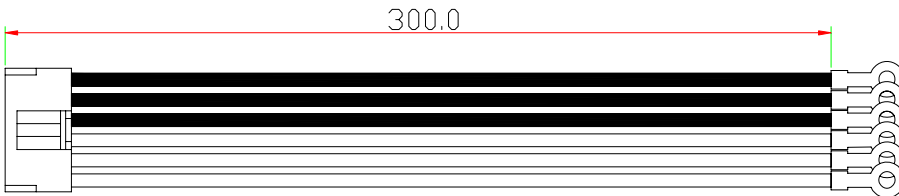

POWER CABLE

ITEM		VENDOR	MODEL NO.	NOTE
CONNNECTOR	DATA	GEOYOUNG	TPHB03-20(L)	
	POWER	YEONHO	GW396-06	
CABLE	DATA	DAECHANG	FC2.54-20P-250MM	
	POWER	DAECHANG	YH396-06P-300R	

BLOCK DIAGRAM

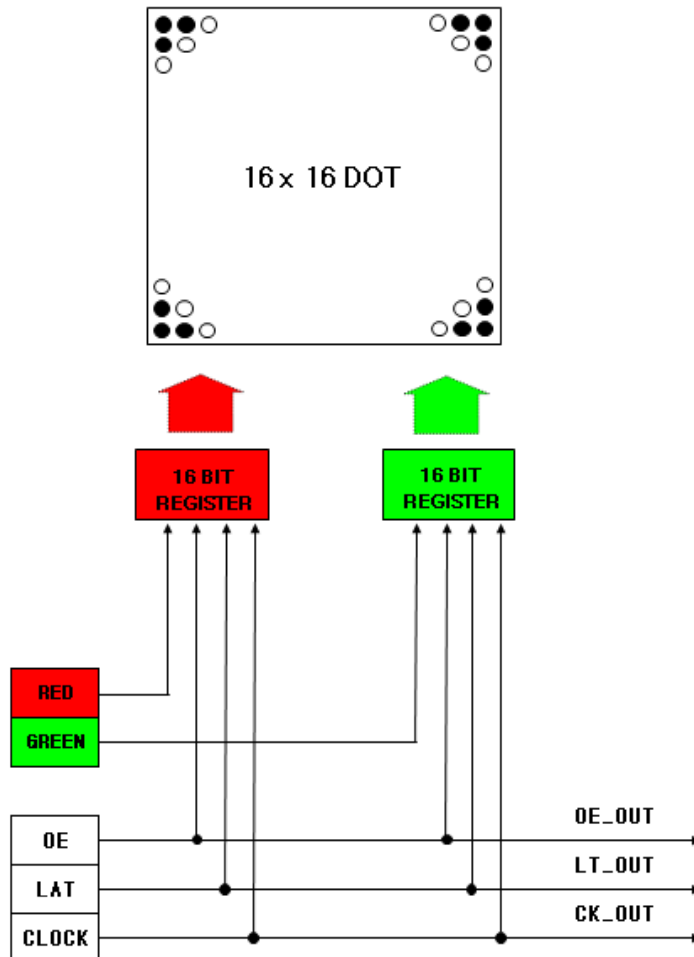

KPM-300LA-16AS21

FRONT SIGNAL

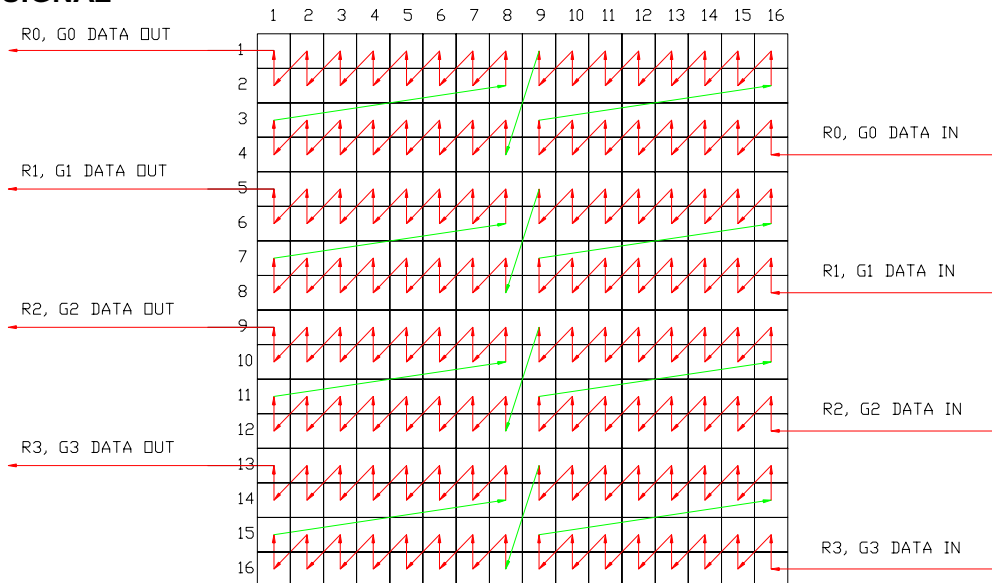

INSTALLMENT NOTICES

- 1). Please apply this modules at a safe surrounding against noise because the error or mis-operation may occur at fragile place of noise. Therefore consider the place you will install.
- 2). Check surely the power condition previous to operation test in order to prevent module damage which might be caused by the excessive power.
- 3). Water proofing is not covered. Therefore we recommend water proofing at least in the front of modules.
- 4). Modules should be set up within the guarantee limitation and especially kept away from salt, dust, soot and **SO₂ GAS** etc.
- 5). When there is no data transmission at operation test, just turn power off immediately. Otherwise operating circuit gets damage.
- 6). Please apply this product under the range of guarantee, considering the sufficient radiation in case of the assembled multi-module.
- 7). V_{LED} is recommended the maximum of rating voltage for best result under the low temperature such as -15°C below.
- 8). Please check the insert direction when you attach SIGNAL CONNECTOR or link the power.
(Refer to Harness wire colors of which the insert direction is same.)

REFERENCES

- 1). Check **SYSTEM** weight before apply modules into housing
- 2). Operation test or anti-static electricity need for the **CMOS** attached in circuit board.
- 3). Sufficient power capability is necessary to deal with the excessive power which might be drastically caused depending on the condition of the on/off of unit.(Peak Current times 1.5 and higher)
- 4). Power for Logic or **LED** requires Switching Mode Power Supply.
- 5). Use power bus bar when connecting power.
It helps power to keep from falling down.
- 6). Please don't change "switch for luminance adjustment".
The switch was set as outgoing.
- 7). Any further question or trouble herein will be worked out mutually by customer and supplier through sales manager.